

#-6504 JOBE Yellowjacket 45 inch sluice

JOBE Sluice Instructions

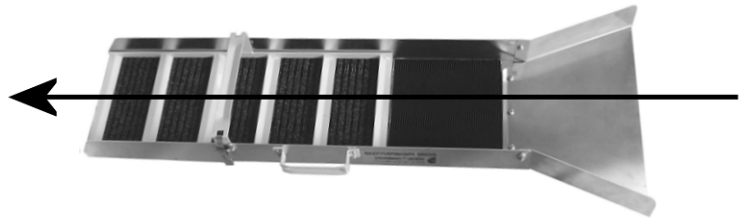
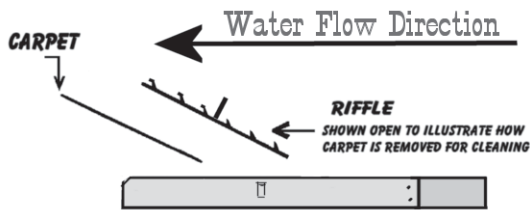

Thanks for purchasing your new JOBE stream sluice. JOBE sluices are designed with a riffle set containing both Hungarian and stream riffles. See the illustration below. Both types of riffles are designed to create turbulence that deposits the gold and other heavier values behind the riffles. The first three riffles in the sluice are stream riffles, that are shorter and designed to work with minimum water flow. These are followed by three Hungarian riffles which work better with a more aggressive volume of water. Therefore the JOBE sluices work well in a wide variety of circumstances.

Instructions:

Place the sluice in the flow of a stream or river so that the water enters the flared end and flows through the sluice. If the current is strong you may need to lay some stones against the edge of the sluice to keep it from washing away.

The sluice should be set at a downhill angle that allows the material to briskly flow through the sluice. The higher the volume of water available the shallower the angle will be. The important factor is that the material you shovel into the sluice will flow through the sluice. Sometimes you will find that it helps to classify the material before you put it into the sluice by passing the material through a screen. Preclassified material will run through the sluice at a more uniform rate.

Shovel material into the sluice at the flared end as close to the end as possible so that the material is washed over the entire length of the sluice.

Do not overload the sluice with material. Pace your shoveling so that the sluice has time to clear before you add more material.

When you are ready to clean out the concentrates remove the sluice from the water and tip it down into a bucket or tub. Wash as much material as possible out of the sluice into the tub and then remove the riffle tray and carpet and wash both of them out into the tub. Replace the carpet and riffle tray into the sluice and you are ready to go again. The concentrates of heavier material and gold are now in the tub so that you can remove the gold from the concentrates with a gold pan or some other clean up tool.

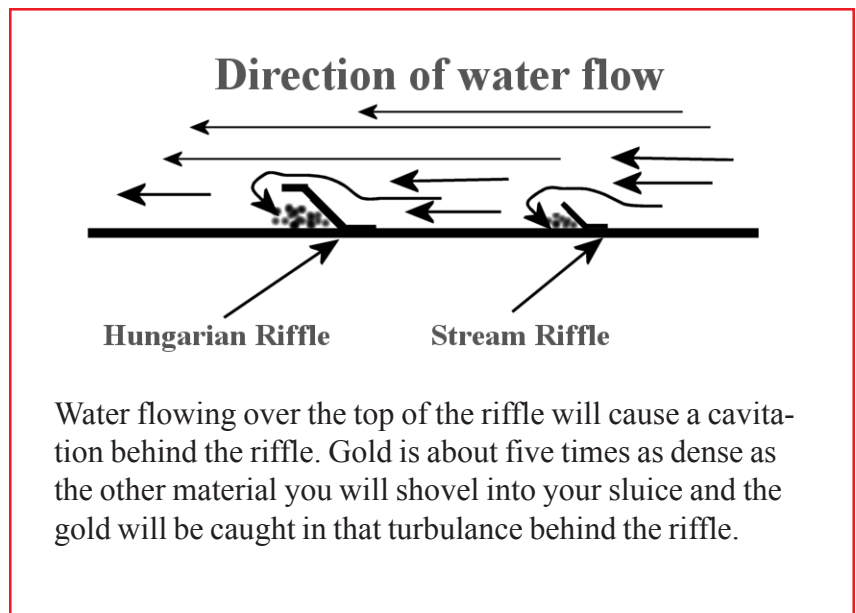

Water flowing over the top of the riffle will cause a cavitation behind the riffle. Gold is about five times as dense as the other material you will shovel into your sluice and the gold will be caught in that turbulence behind the riffle.

Sluice Accessories

A number of accessories are available for your JOBE stream sluice that can improve the performance as for a particular application of the sluice or convert the sluice into another recovery tool.

RIBBED VINYL MAT

Black ribbed vinyl matting added to your sluice gives instant recognition to see the presence of gold without needing to clean the sluice. This product is also used in "poop tubes" and other cleanup appliances. The overall height of the mat is 60/1000th of an inch and the depth of the groove is 30/1000th of an inch.

#-5732 12" x 24"

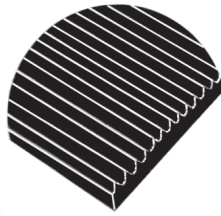

Low Profile mat side view

TUFF-STUFF DEEP V GROOVED MAT

Rugged but lightweight this product is specially made for us to provide a deep vee rubberized mat tough enough to stand up to the rigors of prospecting but thin enough to not require special applications. The overall height of the mat is 150/1000th of an inch and the depth of the groove is 110/1000th of an inch.

#-5742 12" x 24"

#-5741 12" x 48"



Tuff-Stuff mat side view

MINERS MOSS

Nomad matting is the same ultimate matting for gold recovery in any sluicing or dredging situation. Traps and holds gold inside woven vinyl fibers. Preferred by commercial dredgers.

#-5083 12"x36"

JOBE 4 Leg Universal Sluice Stand

This powder coated steel sluice stand is designed to easily bolt on to any sluice and provide a sturdy platform to use the sluice as a hibanker, power sluice, or dredge. The 3/4 inch square tubular legs are independently adjustable for leveling or setting any angle on any terrain. The forward legs are 16 inches long and the rear legs are 20 inches long. The entire kit weighs 5 pounds. All mounting hardware and instructions are included. #-6501



JOBE Power Sluice Header Box

Converts your stream sluice into a power sluice or hibanker. All precision laser cut aluminum construction. Works on the JOBE 45 Yellow Jacket, the Keene A52, or any 10 inch wide sluice. The mounting holes are pre-cut to bolt onto the JOBE sluice and the JOBE sluice stand. Mounting to the Keene A52 requires two 1/4" holes to be drilled on the sides of the header box. Weighs only 3 pounds. #-6505

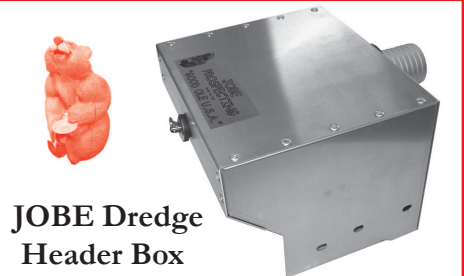

JOBE Dredge Header Box

The JOBE Dredge Header Box is used to convert your stream sluice into a 2 inch dredge. All precision laser cut aluminum construction. Works on the JOBE 45 Yellow Jacket, the Keene A52, or any 10 inch wide sluice. The mounting holes are pre-cut to bolt onto the JOBE sluice and the JOBE sluice stand. Mounting to the Keene A52 requires two 1/4" holes to be drilled on the sides of the header box. Weighs only 3 pounds. #-6507

JOBE Hibanker / Dredge Hopper

Use this quality precision laser cut aluminum Hibanker / Dredge Hopper to convert your stream sluice into a Hibanker or dredge. The classifier screen is removable and is made of plated steel. The top of the hopper is 18 inches x 18 inches with spray bars. The water inlet is equipped with a 1 1/2 inch slip fitting which can be removed to use 1 1/2 inch pipe fittings. The water supply can be adjusted with a valve which is included. Comes ready to go as a 2 inch dredge hopper and can be easily modified to use with a 2 1/2 inch dredge. Works on the JOBE 45 Yellow Jacket, the Keene A52, or any 10 inch wide sluice. The mounting holes are pre-cut to bolt onto the JOBE sluice and the JOBE sluice stand. Mounting to the Keene A52 requires two 1/4" holes to be drilled on the sides of the hopper. Total weight is just 14 pounds. The removable classifier screen is precision laser cut from a single piece of steel and then plated..

#-6508

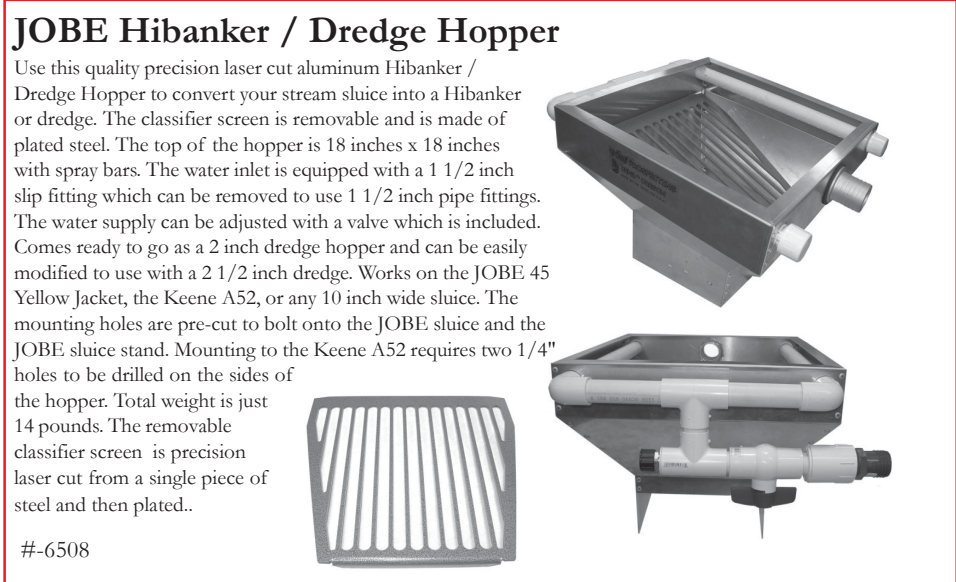

JOBE 12 Volt Magnum Power Sluice

The JOBE Magnum Power Sluice is designed around the JOBE 48 inch Yellow Jacket sluice. Attaching the JOBE adjustable 4 leg stand, the JOBE Power Sluice header box, and the Mayfair 2000 gallon-per-hour 12 volt pump all adds up to a very good hi-volume power sluice. It can also be set up with a recovery tub to complete a power sluice recirculating system. Includes 8 feet of 1 1/2 inch discharge hose.

#-6527



JOBE 1.5 inch SuctionDredge

The JOBE 1 1/2 inch dredge is designed around the JOBE 48 inch Yellow Jacket stream sluice. The JOBE adjustable 4 leg stand and the JOBE Dredge Header Box are attached to the sluice. Powered by a 2.5 horse power, 4-cycle, gasoline pump. The pump and engine combination weighs only 27 pounds and is mounted on a shock-resistant base plate. This unit comes complete with everything you need for a 1.5 inch dredge including all the parts, hoses and clamps. The sluice also comes with an aluminum flare, not shown, which replaces the Dredge Header Box so that the sluice can also be used as a normal stream sluice.

#-6523

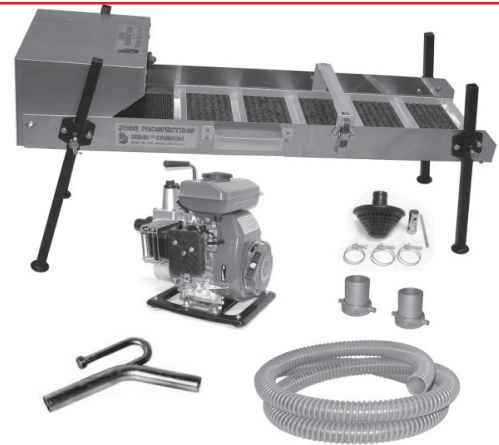

The JOBE Power Sluice / Hibanker

The JOBE Power Sluice is designed around the JOBE 48 inch Yellow Jacket stream sluice. The JOBE adjustable 4 leg stand and the JOBE Hibanker Hopper are attached to the sluice. Powered by a JOBE 2 1/2 hp, 4-cycle, gasoline pump. The pump and engine combination weighs only 27 pounds and is mounted on a shock-resistant base plate with a carry handle. It can also be set up with a recovery tub to complete a hibanker recirculating system. Includes 8 feet of 1 1/2 inch intake hose, an intake screen, 25 feet of 1 1/2 inch lay-flat discharge hose, and all necessary fittings. The sluice also comes with an aluminum flare, not shown, which replaces the Power Sluice Header Box so that the sluice can also be used as a normal stream sluice.

#-6529

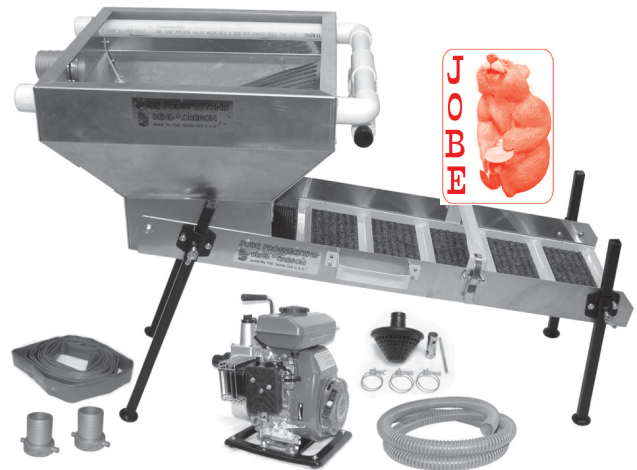

JOBE 2 inch Suction Dredge/ Hibanker Combo

The JOBE Power Sluice and 2 inch dredge combo is designed around the JOBE 48 inch Yellow Jacket stream sluice. The JOBE adjustable 4 leg stand and the JOBE Hibanker Hopper are attached to the sluice. Powered by a Power Lift 6.5 horse power, 4-cycle, gasoline pump. The pump and engine combination weighs only 54 pounds and is mounted on a shock-resistant base plate inside a roll cage. This unit comes complete with everything you need to use it as either a hibanker or as a 2 inch dredge including all the parts, hoses and clamps. The sluice also comes with an aluminum flare, not shown, which replaces the Power Sluice Header Box so that the sluice can also be used as a normal stream sluice.

#-6521

